

# MultisafeWay

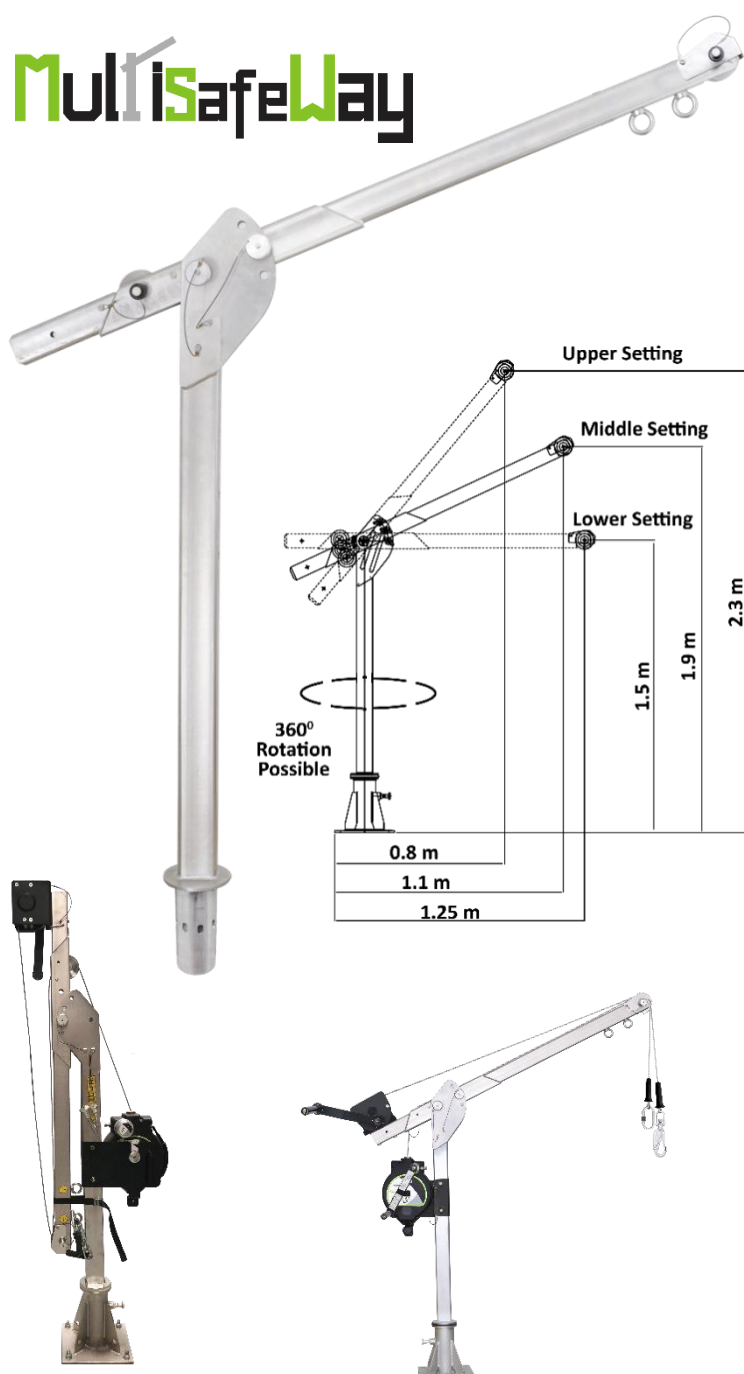

- Davit arm for access in confined spaces or works on a frontage.
- Having two eye bolts at lifting arm as attachment points.
- Provided with special stainless-steel fasteners for fitting of our Winch ref. FA 60 003 20 (20 m) or ref. FA 60 003 30 (30 m).
- To be used with our retractable fall arrester with integrated rescue winch ref. FA 20 401 20 (20 m) or ref. FA 20 401 30 (30 m).

- Can swivel a complete 360 degrees on its mounted base - 8 positions.
- Lifting arm is adjustable at 3 defined points (2.30 m / 1.90 m / 1.50 m), can be folded against the leg and fixed with the included webbing to facilitate transport of the davit arm.
- The davit arm can be moved from one mounting bracket to another.
- Strength of anchorage points greater than 12 kN.

### ACCESSORIES (NOT INCLUDED)

- 2 mounting brackets for fixing the davit arm:
  - 1 for floor mounting, ref. FA 60 022 01,
  - 1 for wall mounting, ref. FA 60 022 02.
- 2 adaptation plates for installing a retractable fall arrester with integrated winch:
  - 1 plate for 20 m retractable fall arrester, ref. FA 60 022 04,
  - 1 plate for 30 m retractable fall arrester, ref. FA 60 022 03.

- **Maximum load capacity:** 300 kg.

**Compliance:** EN795:2012 Type A.

- **Material:** Stainless steel.

|                                    |           |                            |
|------------------------------------|-----------|----------------------------|
| <b>Height:</b><br>1.50 m -> 2.30 m | <b>CE</b> | <b>Weight:</b><br>34.87 kg |
|------------------------------------|-----------|----------------------------|

### KRATOS SAFETY

689 Chemin du Buclay  
38540 Heyrieux – FRANCE

Tel : +33 (0)4 72 48 78 27

Fax : +33 (0)4 72 48 58 32

[www.kratossafety.com](http://www.kratossafety.com) / [info@kratossafety.com](mailto:info@kratossafety.com)

### HS CODE

7610 90 10

### CARTON SIZE / PIECES

168 x 34 x 25 cm / 1

### CERTIFICATE OF TEST SPC0223656/1414 I1 E3

### Satra Technology Centre, N°0321

Wyndham Way, Telford Way, Kettering  
Northamptonshire, NN16 8SD, United Kingdom

### ARTICLE 11 GB07/73551

### SGS United Kingdom Ltd., N°0120

Unit 202B, Worle Parkway,  
Weston-super-Mare, BS22 6WA, United Kingdom